

# Clamshell Buckets



## KG 10-2 Series



### Features

- Flat, compact design thanks to horizontally mounted hydraulic cylinder
- Bottom edges made from high-strength fine-grained steel (450 HB)
- Two heavy-duty synchronized steering

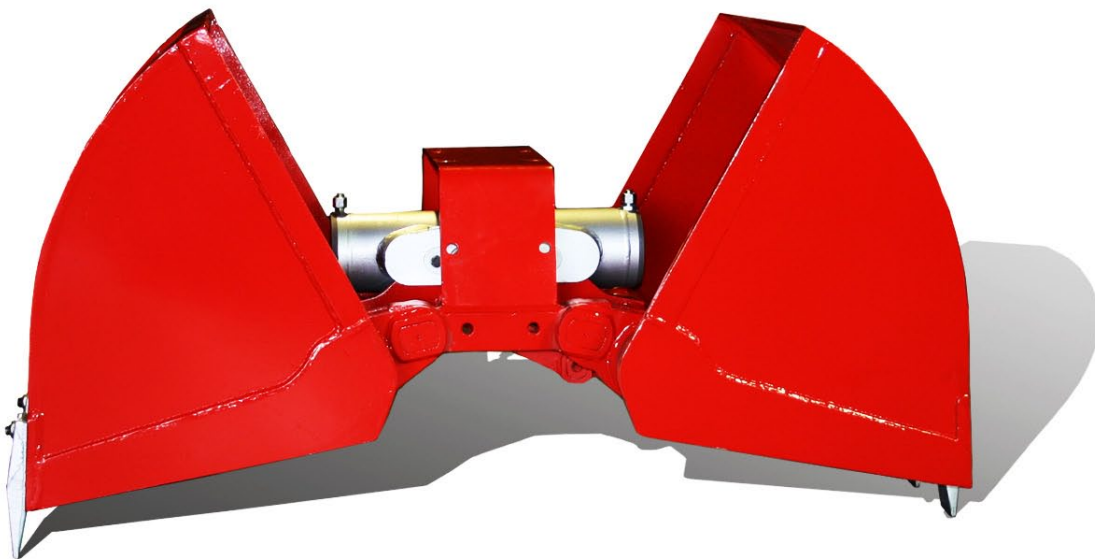

### Range of use: mobile cranes and excavators

Versatile mobile crane grab for several fields of application and material handling, for instance:

- Excavation and bulk goods handling
- Digging ditches
- Handling soil, gravel and sand

Suitable for mobile excavators with a service weight of 5-9t.

### Available accessories and tools

- Hydraulic rotator with endless rotation – with or without grab pressure limitation
- Hose protection bracket for hydraulic rotator connections
- Forged 2-hole bolt-on teeth
- Bolt-on compression rails for handling curbstones
- Hose sets and mounting brackets for all well-known loader crane and excavator brands
- Suspension link with swing brake
- Bolt-on load hook
- Custom-built buckets
- Custom equipment upon request

# Technical Specifications

## KG 10-2 Series

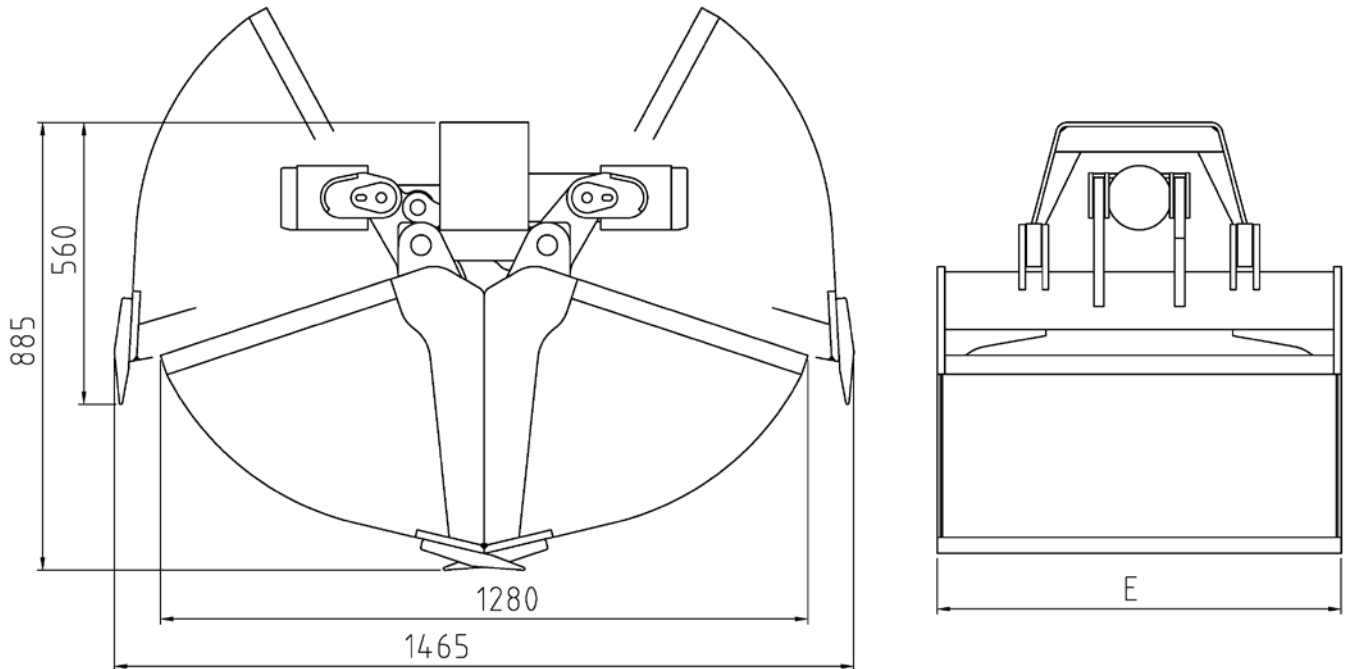

Type	Capacity l	Weight kg	Width of cut E mm	Teeth (option) pieces
KG 10-2-550	275	270	550	6
KG 10-2-650	325	285	650	6
KG 10-2-800	400	320	800	8
KG 10-2-900	450	335	900	8
KG 10-2-1000	500	350	1000	8

Other sizes and series available upon request · Subject to technical modifications!

**Maximum load capacity:** grab: 2t  
**Bulk density:** up to 2t/m<sup>3</sup>  
**Maximum working pressure:** grab function: 300 bar  
**Maximum closing force:** 32 kN  
**Connections – cylinders:** M18x1.5  
**Capacity:** grabbing: max. 35l/min

### Special design

Guard rail grab:

